

# ELLISCO KYORITSU ESSENTIAL TEST & INSTRUMENTATION GUIDE 2024



# CLAMP METERS

## AC Digital Clamp Meter KEW 2117R

- Fully Safety jaw
- Ergonomic over-molded body gives convenient one-hand operation
- Large easy-to-read display with 0.01A resolution
- Accurate reading with True RMS60/600/1000A auto-ranging
- Long battery life
- Safety Standard IEC 61010-1 CAT IV 300V / CAT III 600V



TRUE RMS    $\phi 33$    MAX 1000A   AC A   DC AC V   NCV    $\Omega$     $\text{---}$    DATA HOLD

AUTOPOWER SAVE



True RMS function for accurate readings also in presence of modern loads such as LED lamps, motor inverters, PCs, TVs, Air conditioners, etc.

Waveform	True RMS type <i>TrueRMS</i>	Averaging value type
	✓ correct reading	✓ correct reading
	✓ correct reading	higher reading
	✓ correct reading	lower reading
	✓ correct reading	lower reading

Scan the QR Code To Download the full Kyoritsu Catalogue



## AC/DC Digital Clamp Meter KT 203

- Small and handy clamp meter
- IEC 61010-1 Safety Standard CAT IV 300V, CAT III 600V
- 400A AC/DC Clamp meter
- DMM function ACV, DCV,  $\Omega$ , Continuity Buzzer.



$\phi 30$    MAX 400A   DC AC A   DC AC V    $\Omega$     $\text{---}$    DATA HOLD   AUTOPOWER SAVE



# MULTI FUNCTION METERS

## Multi Function Tester KEW 6516

A lot of testing power in the hands of Electrical Installation Professionals



### 12 in 1

<b>Insulation</b> 100/250/500/1000V	<b>Loop</b> 2/20/200/2000Ω	<b>RCD</b> 10/30/100/500/1000mA
<b>PSC</b> 2000A/20kA	<b>PFC</b> 2000A/20kA 2000A/50kA	<b>Earth</b> 20/200/2000Ω
<b>ACV</b> 300V/600V	<b>Continuity</b> 20/200/2000Ω	<b>Phase rotation</b>
<b>Frequency</b>	<b>SPD(Varistor)</b>	<b>PAT</b>

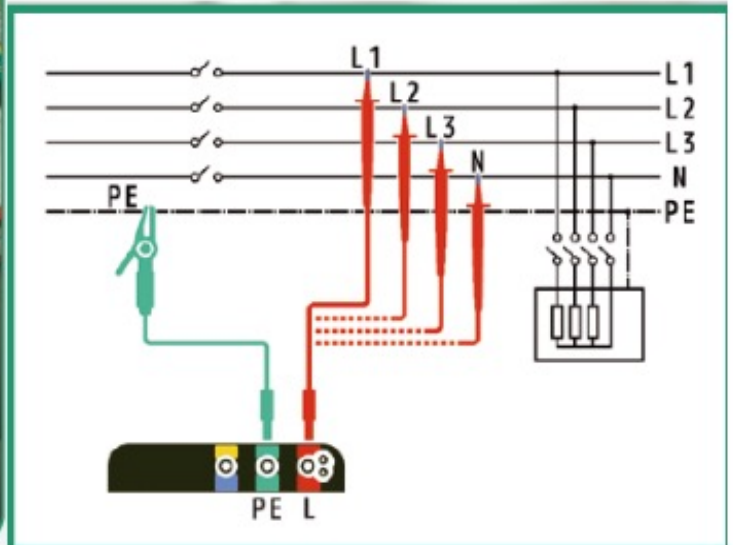

### KEW 6516BT



 MODEL 7187A, 7218A, 7221A, 7222A	 MODEL 7281	 MODEL 7246/7247	 MODEL 7228A	 MODEL 8041
 MODEL 9084	 MODEL 9142	 MODEL 9151	 MODEL 9199	 MODEL 0212-USB

# MULTI FUNCTION METERS

## Multi Function Tester KEW 6010B

- Continuity: 20/200Ω 200mA Test Current
- Insulation: 500/1000V, 20/200MΩ 1mA Rated Test Current
- Loop Impedance: 20/2000Ω 15mA Test Current at RCD: 10/30/100/300/500mA x1/2, x1, Fast Trip (40ms), DC, Auto Ramp
- Test of a large kind of RCD's: Standard, Selective, AC and A (DC sensitive breakers)
- Uc (Contact Voltage): 100V
- Designed to IEC 61010-1, IEC 61557
- Data Memory: 300 measured results
- The stored data can be transferred to PC via Optical Adaptor Model 8212-USB or 8212-RS232C.



Scan the QR Code to visit our online website



# EV CHARGING ADAPTOR

## NEW - EVSE Adaptor KEW 8602

Dedicated adapter for EVSE (Electric Vehicle Supply Equipment) installation inspections, maintenance and troubleshooting  
Compact adapter for complete testing of Mode 3 AC EVSE

- EVSE tests under various simulations
  - CP State / PP State simulation
  - CP Error / PE Error simulation
- Touch pad for PE voltage check
- L1, L2, L3, N, PE measuring terminals for electrical tests of EVSE
- CP signal terminals for CP signal monitoring
- Mains socket for load current test (MAX. 10A)
- CAT II 300V rating



What you can do with KEW 8602

### Live LED

Lights up when the voltage is LIVE.



### Measuring terminals

PE, N, L1 (Single phase)  
PE, N, L1, L2, L3 (Three phase)

### CP signal output terminals

Terminals for measuring CP signals with oscilloscope, etc.

### PE PRE-TEST

Touch pad to test for dangerous voltages present on the PE.

### CP error simulation button

The case of an earth fault in the CP line can be simulated. While this button is pressed, the EVSE output is stopped.

### PE error simulation button

This button can be used to simulate the case of a broken earth wire. While this button is pressed, the EVSE output is stopped.



### CP(Control Pilot) state selector

By operating this selector, the connection state of the vehicle can be simulated.

### PP(Proximity Pilot) state selector

This selector can be used to simulate the rated capacity of the cable in the Untethered EVSE.

Log test results with KEW Connect

Use the application KEW Smart Advanced to improve work efficiency.

KEW 6516BT can transfer the test data to a Tablet or Smartphone via Bluetooth.

Such test data can be saved, shared and sent



# INSULATION RESISTANCE TESTERS

## Analogue Insulation / Continuity Tester MODEL 3132A

- Dust and drip proof construction. (designed to IEC 60529 IP54)
- Designed to meet IEC 61010-1 and IEC 61557 safety standard.
- 1mA rated test current at the minimum resistance.
- 200mA measuring current on continuity testing.
- Automatic discharge of circuit capacitance. (Any charge stored in the circuit under test will be automatically discharged after testing.)
- Live circuit warning buzzer and neon lamp.
- Small and lightweight. Shock resistant new case material.
- AC voltmeter with linear, easy-to-read scale.
- Operates on AA, R6 × 6 dry batteries.

AC V Ω 250V 500V 1000V



## Digital Insulation / Continuity Tester MODEL 3005A

- Bar graph to display insulation resistance.
- Displays the value of external AC voltage along with flashing symbol.
- Auto null function to automatically subtract the test lead resistance before displaying the real continuity resistance value.
- Live circuit warning beeper.
- Releasing the test button automatically discharges the charges stored in the circuit under test.
- 200mA continuity measuring current to IEC 61557.
- Minimum 1mA current on insulation tests to IEC 61557

AC V Ω AUTO POWER OFF 250V 500V 1000V



# PORTABLE APPLIANCE TESTERS

## Portable Appliance Tester KEW 6205

Protect life and property from faulty appliances

- Battery operated
- PASS / FAIL result
- Colour status back light
- 10 mA & 30 mA RCD test (Isolation transformer built in)
- Memory function up to 999 data
- Printer output
- Complies to AS / NZS 3760

KEW 6205 equipped with Wireless LAN is available only in Australia and New Zealand.



This instrument is suitable for performing tests as required by the following standards.  
AS/NZS 3760 In-service safety inspection and testing of electrical equipment.

### ● Included Accessories



### ● KEW 6205 Function

Function	Tests of contents
Class I Test	<ul style="list-style-type: none"> <li>• Protective conductor resistance (Test current 200mA DC nominal)</li> <li>• Insulation resistance test (250V or 500V)</li> <li>• Leakage current test (100-253V/50Hz)</li> <li>• Load current test (100-253V/50Hz)</li> </ul>
Class II Test	<ul style="list-style-type: none"> <li>• Insulation resistance test (250V or 500V)</li> <li>• Leakage current test (100-253V/50Hz)</li> <li>• Load current test (100-253V/50Hz)</li> </ul>
Extension Lead Test	<ul style="list-style-type: none"> <li>• Protective conductor resistance (Test current 200mA DC nominal)</li> <li>• Insulation resistance test (between Line/Neutral-Earth short, Line/Neutral)</li> <li>• Leakage current test (100-253V/50Hz)</li> <li>• Polarity test</li> </ul>
RCD Test	<ul style="list-style-type: none"> <li>• RCD test (10mA/30mA)</li> </ul>

### ● Colour status back light

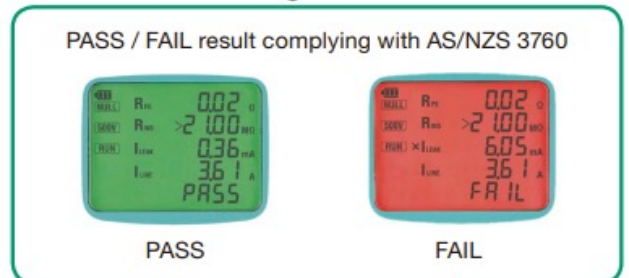

# PORTABLE APPLIANCE TESTING PRO PRINT KIT

## Kyoritsu 6205 PRO PRINT KIT

Features at a glance

- Complies to AS/NZS3760 Standard
- Compact system fits into a handy padded bag for portability
- Full wireless connectivity
- Hand Held Battery Operated
- Pass/Fail result with colour (Red/Green) status backlight
- Printer compatible for customised tag printing
- Memory for up to 999 test results with automatic memory storage
- 15A capability with supplied 15A test lead
- 12 Month subscription to Clevermode App for full asset management and reporting
- Provides tests for:
  - Class I and Class II appliances
  - Extension Leads
  - RCD 10mA/30mA with built in isolation transformer



The 6205PROPRINTKIT comes with:

- 6205PRO Wireless enabled tester
- Compact Toshiba thermal printer with charger and belt clip
- 12 month subscription to Clevermode App
- One roll of white labels
- Padded Kyoritsu carry bag

**Note:** Tablet for illustration purposes only. Not supplied as part of the kit



# DIGITAL MULTI METERS

## Digital Multimeter KEW 1021R

- Elegant and easy-to-use cabinet
- Large display with 6000 counts and Backlight
- Enhanced current measuring function using an external clamp sensor
- Two detachable holders, flat and wing type
- Accurate reading with True RMS
- Safety Standard IEC 61010-1 CAT IV 300V / CAT III 600V

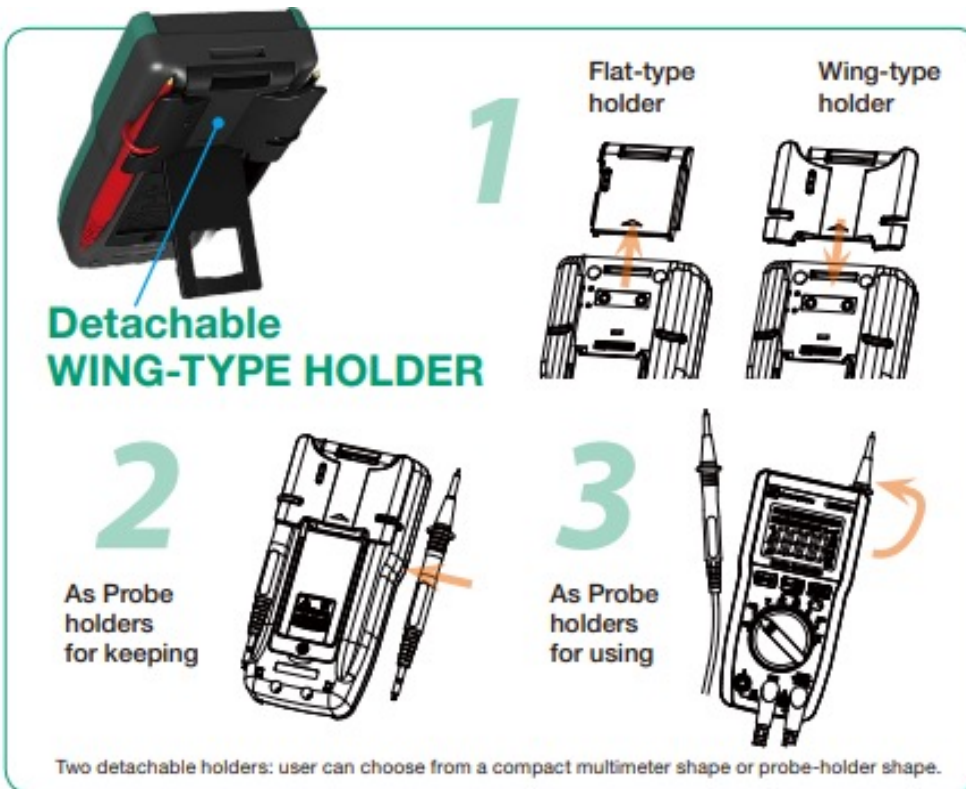

# MORE PRODUCTS AND ACCESSORIES AVAILABLE

## KT 171

- AC and DC voltage tests up to 690V with LEDs and LCD
  - Comply with the latest standards IEC 61243 and IEC 61010
  - Novel design
- Large and bright LEDs: Values are visible in the dark place  
Ergonomic design fits in the hand
- Two functions are available in one model  
"Measurement without battery" and "Self Test (all LED on)"
  - Test leads withstand harsh environments at low temperature
  - Penlight (white LED)
  - Auto-power ON/OFF
  - Audible indication
  - Variable test tips,  $\varnothing 2\text{mm}$  or  $\varnothing 4\text{mm}$
  - Probe protection cover can store the attachment of caps
  - IP65 (IEC 60529)



CAT IV  
600V

## KEW 6315

- Simultaneous Power & Power quality measurements
- Helpful support functions
- Measurement with high accuracy
- Remote monitoring on PC and Android device
- Various Clamp Current Sensors
- Energy consumption check on site
- IEC 61010-1 CAT IV 300V, CAT III 600V, CAT II 1000V



TRUE RMS    USB    Blue tooth    External Power Supply

Scan the QR Code to Download the Full Kyoritsu Catalogue



### MODEL 7269



- Earth resistance test lead (Red)
- 20m

### MODEL 7270



- Earth resistance test lead (Yellow)
- 10m

### MODEL 7271



- Earth resistance test lead (Green)
- 5m

### MODEL 7272



- Consists of
- 7267 (Cable reel for Earth resistance tester [Red])
- 7268 (Cable reel for Earth resistance tester [Yellow])
- 7271 (Earth resistance test lead [Green])
- 8041 (Auxiliary earth spikes [2spikes/1set])
- 9192 (Carrying case)

• Green : 5m, Yellow : 10m, Red : 20m

# SERVICE AND SUPPORT THROUGHOUT NEW ZEALAND

With offices strategically located in Auckland and Christchurch, EllisCo is committed to providing unparalleled service and support nationwide. Our presence extends beyond physical locations, with dedicated staff spread across the country, ready to meet your needs with expertise and efficiency.

## Service and Support Highlights:

- **Nationwide Coverage:** No matter where you are, our extensive network ensures that you have access to our world leading products and services.
- **Experienced Staff:** Our nationwide team comprises industry experts ready to assist you in selecting, implementing, and maintaining the right solutions for your business.
- **24/7 Support:** Your operations are our priority. Benefit from round-the-clock support to address any issues promptly and keep your systems running smoothly.



105 Morrin Road  
St Johns, AUCKLAND 1072



7B Birmingham Drive  
Middleton, CHRISTCHURCH 8024

## AUTOMATION AND SAFETY BRANDS



## LIGHTING AND ELECTRICAL BRANDS



## NATURAL VENTILATION BRANDS





## SHOP ONLINE

With up to date stock levels and trade pricing our Electrical Wholesalers have full access to quickly see stock levels to ensure that you, the customer gets faster responses at any time of the day or on the weekend. With 24 hour access to the EllisCo catalogue and online quotes available we envision to make life easier for everyone.

→ [ellis.co.nz](https://ellis.co.nz)

# ELLISCO

105 Morrin Road  
St Johns, Auckland 1072

7B Birmingham Drive  
Middleton, Christchurch 8024

Phone +64 9 570 5267

Email [info@ellis.co.nz](mailto:info@ellis.co.nz)